

ecospring
HOT WATER SYSTEMS

service✓plan





Ecospring Service Plan

The EcoSpring hot water system you have purchased requires annual servicing to not only extend the life of the system but keep the system performing as efficiently as possible. With proper maintenance, you'll ensure the best performance, cost savings and longevity of your EcoSpring hot water system.

ECOSPRING ES300+

Air filter clean

- The air inlet filter requires an inspection and cleaning every 3-6 months. More often if the unit is installed in an area where there is construction dust or pollen etc.
- The air inlet filter is situated on the top of the unit on the right-hand side. There is a locking ring that needs to be manually turned anti - clock wise to unlock and remove.
- The inlet filter then can be removed and cleaned under the tap and dried before refitting.
- If there is a rain cover fitted to the top of the system, the lid of the rain cover can be removed (4 x screws to be undone to access.)

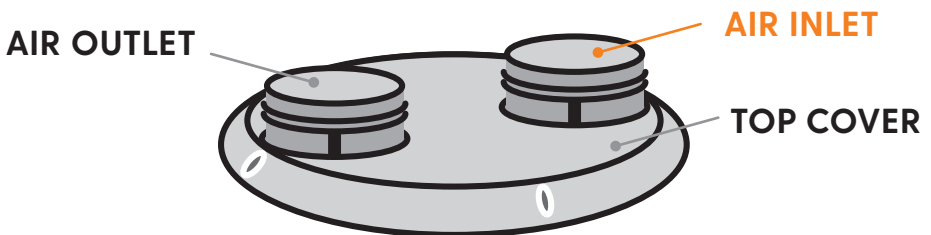

How to Take Off The Air Filter, remove screw from top cover.

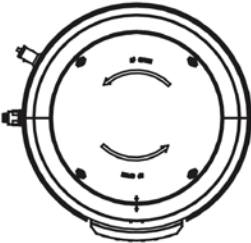

Rotate TOP COVER
counter clockwise

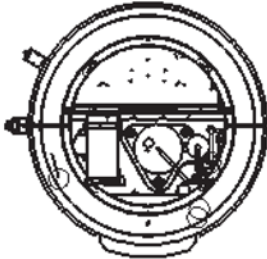

Take the top cover
and slide out the filter

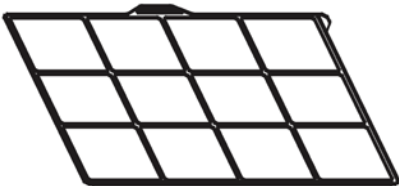

IMPORTANT - Sacrificial Anode

- The sacrificial anode will need to be inspected annually and replaced every 2-3 years to prolong the life of the hot water system. Failure to replace the sacrificial anode will potentially cause failure of the element and eventually the internal cylinder itself.
- The anode can be removed with a 27mm mechanics socket by a registered plumber or one of our local service agents.

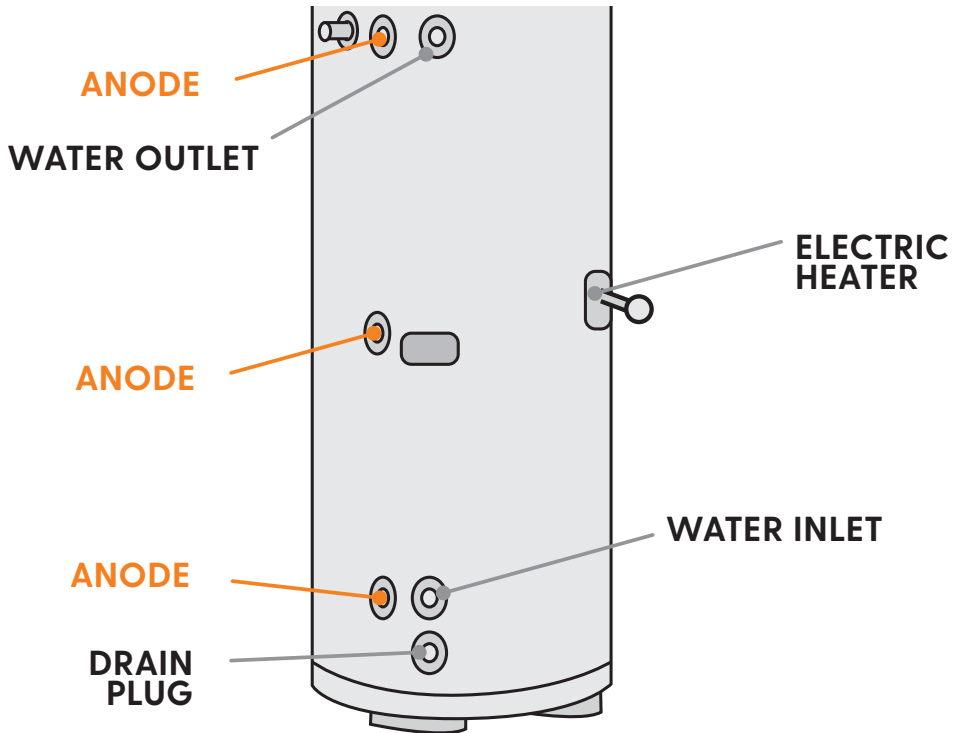

ECOSPRING - ES300+/HP300

IMPORTANT - How to Change the anode

Turn off the power, and turn off the water inlet valve.

Open hot water tap, and decrease the pressure of the inner container.

Open the drain port, and release about 20L water.

Unscrew anode according to instruction.

Replace with a new anode, and make sure effectively sealed.

Open cold water valve until hot water flows out, and turn off the hot water tap.

Restart and can be used normally.

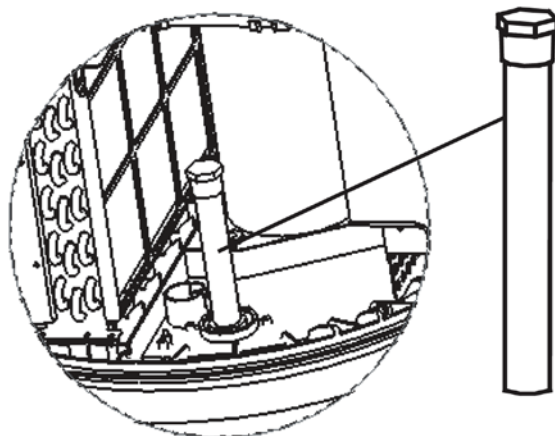

ECOSPRING - ES190

Draining of system

- Draining the cylinder annually will clean any build-up of “sludge” or mineral deposits from the base of the inner tank.
- Isolate the water supply and drain the hot water cylinder.

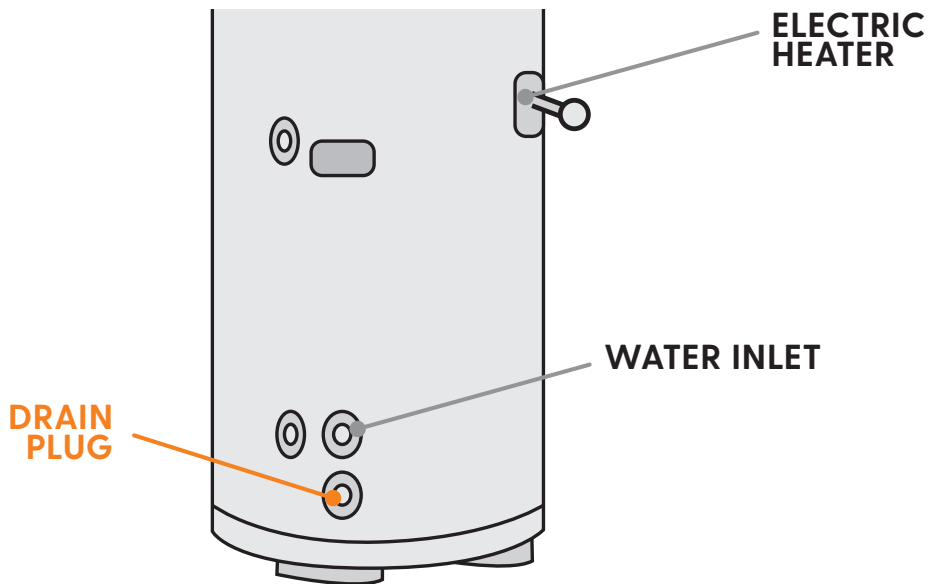

ECOSPRING - ES300+/HP300

Electrical connection inspection

- Please ensure to check all electrical connections and refrigeration levels every 5 years.

Display and system settings

- The front display can be cleaned every 6-12 months. While cleaning the display check the clock settings on the system and reset the time if required.
- Press and hold the enter button for 3 seconds to unlock the screen. (The padlock in the top right-hand corner will be removed)
- Check the temperature settings and adjust to 60 degrees if required.



Operating the PTR valve

- Operating the PTR valve every 12 months will ensure the drains and waterways are clear.

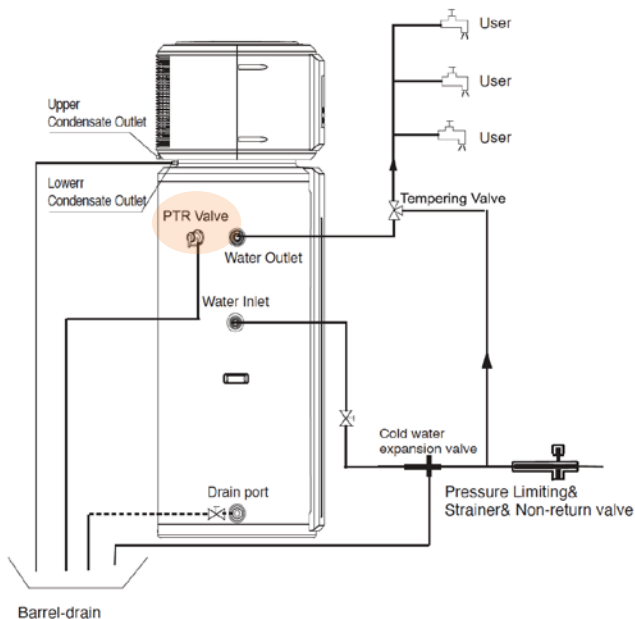

Contact

To book a service agent to come and check your EcoSpring

Call: 0800 200 510

Email: info.parex@emerson.com



Parex Industries Ltd, 5 Tolich Place, Henderson, Auckland 0610
Telephone +64 9 836 6566